

To assemble the Amati Island follow this procedure.

- 1) Place the spacer assemblies on top of the lower cabinet assemblies and use the provided connector bolts to pass through the (4) predrilled holes in the sub top of the lower cabinet into the threaded inserts in the spacer. Tighten with the provided allen wrench.
- 2) Place the upper cabinets on top of the spacer assemblies. Use the provided connector bolts to pass through the (2) predrilled holes in the sub deck of the upper cabinet into the threaded inserts in the spacer. Tighten with the provided allen wrench.
- 3) Assemble the mirror frame by passing the supplied screws into the pre-drilled/tapped holes in the metal. You may wish to cut the side pieces of the mirror frame down to accomodate your ceiling type.
- 4) Place both sides of the island in their final position. Leave a 6 1/16" gap between them. Lower the mirror frame assembly on top of the short base cabinets. Line up the cooresponding holes and secure with the supplied bolts.
- 5) With the cabinets and mirror frame installed, locate the supplied mirror clips and attach to pre drilled holes in the mirror frame. Install mirror by first seating into the bottom clips then lifting the upper clips to seat the top of the mirror.

Quantity -

Finish Schedule - 940-48-1

Face Color -
 Top Color -
 Toe Color - Sliver Legs
 Reveal / Accent Color -
 Hardware - Amati Pulls
 Interior - Black Melamine
 Other (Specify) -

General Notes:

1. All counter tops are to be made removable wherever possible.
2. Items must be broken into managable sections For Shipping. Mark For Ease Of Reassembly.
3. Install Shipping Cleats Wherever Possible To Prevent Shipping Damage.
4. Purchased items Must Be Trial Fit Before Shipping.

 Collins Manufacturing 2000 Bowser Road Cookeville, TN 38506		
Title:		
Size: NTS	Drawing Number: Job	Drawn By:
Date: 10/11/07	Sheet 3 of 7	

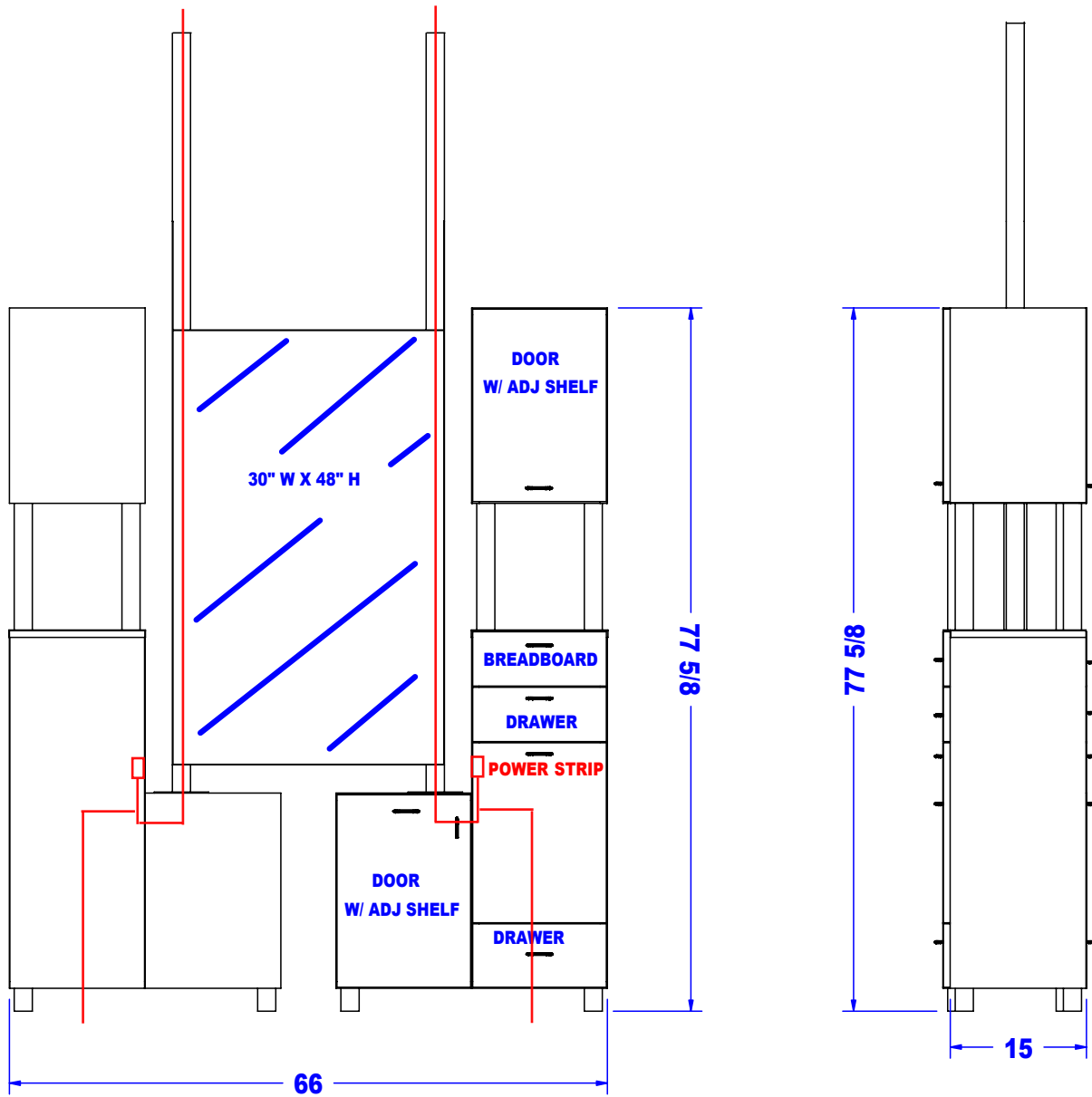

Preliminary
Not For Construction

This drawing is the property of Collins Manufacturing Company and is protected under copyright law.

Quantity -

Finish Schedule - 941-66-1

Face Color -
 Top Color -
 Toe Color - NA
 Reveal / Accent Color - SILVER METAL
 Hardware -
 Interior - Black Melamine
 Other (Specify) -

This drawing represents Collins Manufacturing Company's understanding of the desired item as was previously priced & ordered. Your signature indicates you have reviewed the drawing; and your approval will authorize Collins to initiate the acquisition of materials & subsequent production. More than modest changes may affect the price and/or manufacturing lead time.

- Approved as drawn.
- Approved w/ changes noted.
- Not approved - re-submit.

Signature _____
 Company _____ Date _____

Collins Manufacturing 2000 Bowser Road Cookeville, TN 38506		
Title: _____		
Size: NTS	Drawing Number: _____	Drawn By: Zane
Date: 09/21/07	Sheet	8 of 9

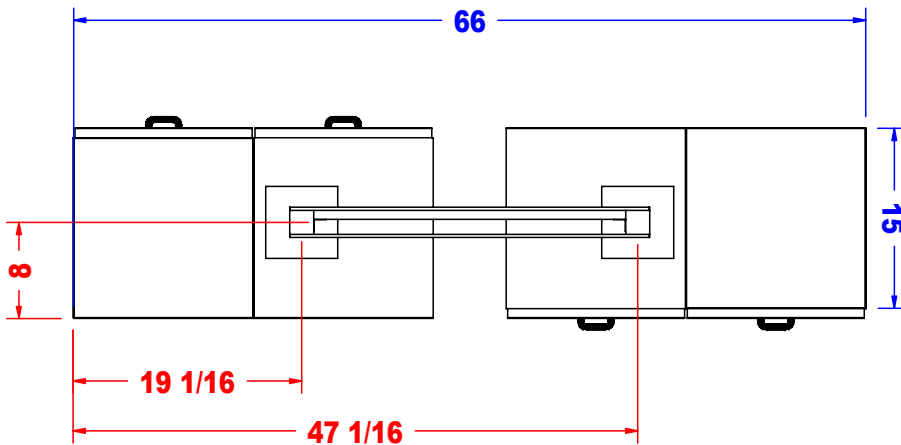

Preliminary
Not For Construction

This drawing is the property of Collins Manufacturing Company and is protected under copyright law.

Quantity -

Finish Schedule - 941-66-1

Face Color -
Top Color -
Toe Color - NA
Reveal / Accent Color - SILVER METAL
Hardware -
Interior - Black Melamine
Other (Specify) -

This drawing represents Collins Manufacturing Company's understanding of the desired item as was previously priced & ordered. Your signature indicates you have reviewed the drawing; and your approval will authorize Collins to initiate the acquisition of materials & subsequent production. More than modest changes may affect the price and/or manufacturing lead time.

- Approved as drawn.
- Approved w/ changes noted.
- Not approved - re-submit.

Signature _____
Company _____ Date _____

Collins Collins Manufacturing
2000 Bowser Road
Cookeville, TN 38506

Title: _____
Size: **NTS** Drawing Number: _____ Drawn By: **Zane**
Date: **09/21/07** Sheet **9 of 9**