

## Hydraulic Styling Chair or All Purpose Chair Assembly Instructions

1. Remove chair top, tubular steel footrest, and hydraulic base from carton; remove and discard the plywood piece from the top of the hydraulic base.

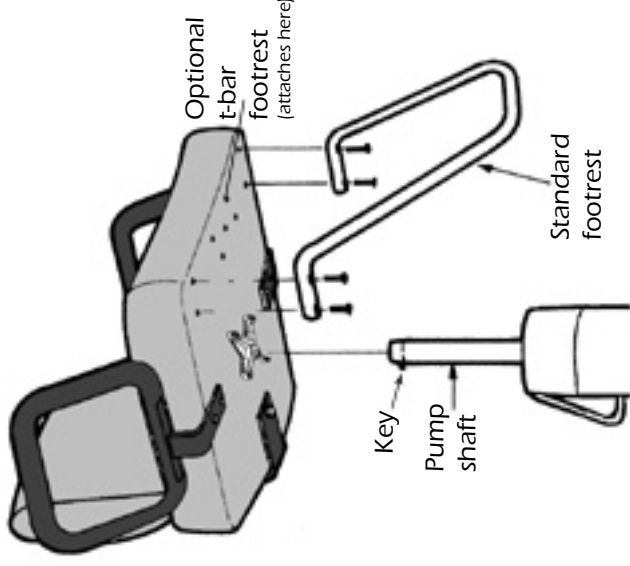

2. Locate bolts and washers in small plastic bag stapled to the bottom of the chair. Align the four holes in the ends of the footrest with the four holes located toward the front of the seat cushion. The holes are underneath the thin black fabric. They can be found by feeling for the indentions or, if required, a pen or the supplied bolts may be used to puncture the fabric to expose the threaded inserts.

3. Using a 7/16" wrench, join the footrest to the seat cushion with the bolts & washers provided. Be sure to use the supplied lock washers & securely tighten the bolts.

4. Place the chair top assembly on the hydraulic base, aligning the "keyway" or slot in the seat casting with the "key" or black pin near the top of the hydraulic base's stem. Sit in the chair to "press" the chair top assembly firmly onto the base. The key is expected to go into the "keyway slot" but not expected to go to the very top of the slot.

5. Make note of the label that is typically placed on the bottom of the chair. It contains the sales order number, model number, and color of the chair. Responsibly dispose of all the packaging materials ... RECYCLE whenever possible.

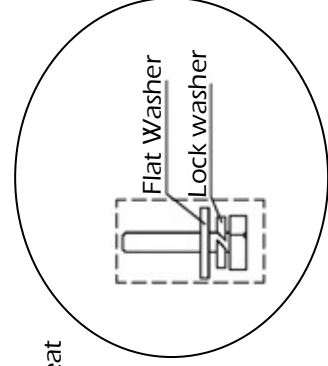

## Spring-Back or Lever-Control Shampoo Chair, Task Chair Assembly Instructions

1. Remove chair top, die cast base, and column assembly from carton.

2. Locate bolts and washers in small plastic bag stapled to the bottom of the chair. Align the four holes in the seat plate with the four holes in the bottom of the seat cushion, insuring that the "straight" side of the seat plate is facing the back mechanism of the chair. (These holes are underneath the thin black fabric. They can be found by feeling for the small indentions. A pen or the supplied bolts may be used to puncture the fabric to expose the threaded inserts.) Using a 7/16" wrench, bolt the seat plate & column assembly to the seat cushion with the bolts & washers provided.

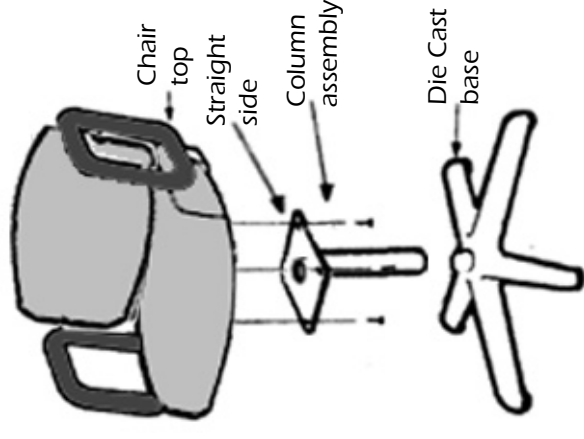

3. Place the tapered end of the column into the hole in the center of the die cast aluminum base. Sit in the chair to "lock" the chair top assembly firmly into the base.

## Care and Maintenance

1. **Vinyl Upholstery:** The vinyl upholstery materials can be cleaned with a 10% solution of liquid dish soap and water applied with a soft damp cloth or, if necessary, applied with a soft-bristle brush. Wipe away residue with a soft water-dampened cloth. To restore luster, occasionally apply a light coat of spray furniture wax, wait 30 seconds, and follow with a light buffing with a clean white cloth.

2. **Hydraulic Base:** Before initial use, pump the chair all the way up and let it down 8 to 10 times to insure proper lubrication of the internal seals. Repeat this procedure every 60-90 days to maintain proper seal lubrication. Generally, no added routine maintenance is required ... but annually applying a light coating of Vaseline to the shaft and moving parts will insure the quietest operation and longest life.

3. **General Cleaning:** Use Windex, Glass Plus, or a similar cleaning product. Follow the directions on the label. Periodic application of a general chrome polish will help to maintain the luster of chrome-plated components.